

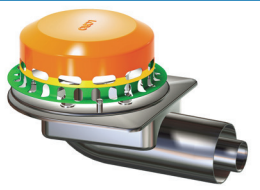

Installation instructions

LORO-X main-emergency scupper drain combination

with clamping flange, steel, hot-dip galvanised,
for bituminous or plastic roof sealing sheets, according to EN 1253

System overview

	LORO-X main-emergency combination Scupper drain	LORO-X sliding flange for bonding the bituminous vapour barrier	LORO-X sliding flange for bonding the plastic vapour barrier
with clamping flange for bituminous and plastic sealing sheets DN 100/50	 13506.100X	 13235.100X	 13236.100X

Construction diagram

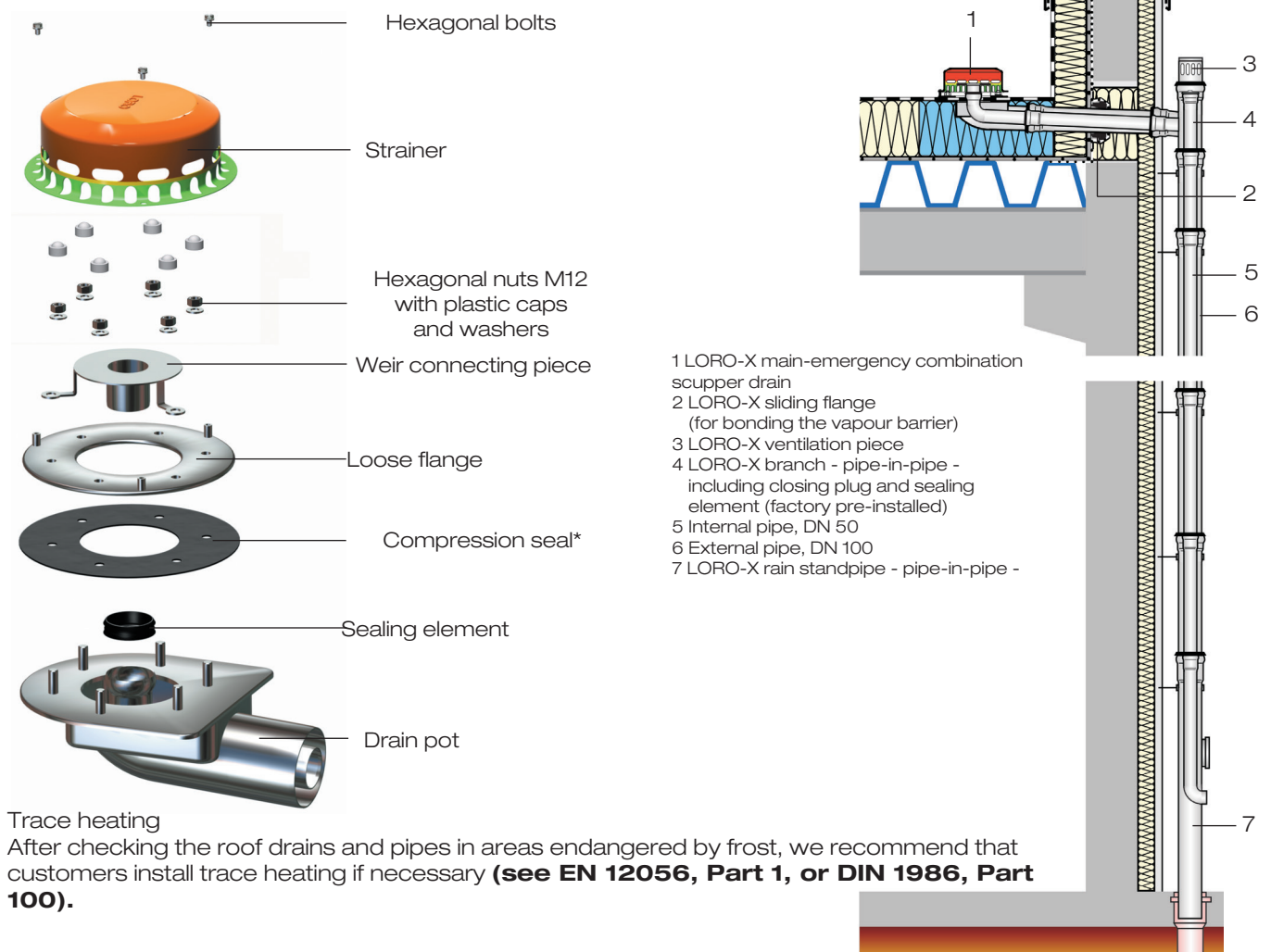

1. Integration of the LORO-X main-emergency combination scupper drain into the roof structure

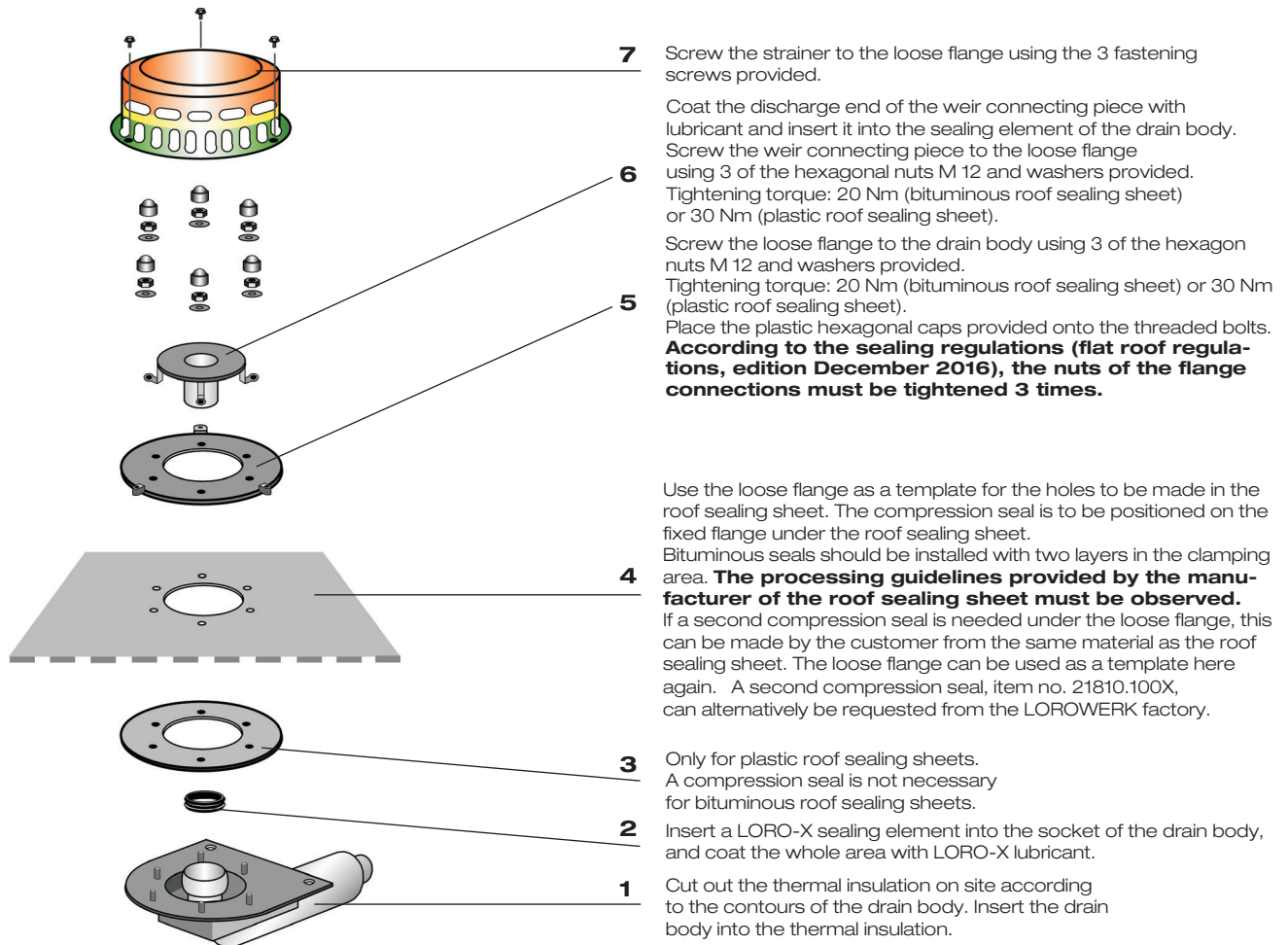

- 7** Screw the strainer to the loose flange using the 3 fastening screws provided.
- Coat the discharge end of the weir connecting piece with lubricant and insert it into the sealing element of the drain body. Screw the weir connecting piece to the loose flange using 3 of the hexagonal nuts M 12 and washers provided. Tightening torque: 20 Nm (bituminous roof sealing sheet) or 30 Nm (plastic roof sealing sheet).
- 6** Screw the loose flange to the drain body using 3 of the hexagon nuts M 12 and washers provided. Tightening torque: 20 Nm (bituminous roof sealing sheet) or 30 Nm (plastic roof sealing sheet).
- 5** Place the plastic hexagonal caps provided onto the threaded bolts. **According to the sealing regulations (flat roof regulations, edition December 2016), the nuts of the flange connections must be tightened 3 times.**

Use the loose flange as a template for the holes to be made in the roof sealing sheet. The compression seal is to be positioned on the fixed flange under the roof sealing sheet. Bituminous seals should be installed with two layers in the clamping area. **The processing guidelines provided by the manufacturer of the roof sealing sheet must be observed.** If a second compression seal is needed under the loose flange, this can be made by the customer from the same material as the roof sealing sheet. The loose flange can be used as a template here again. A second compression seal, item no. 21810.100X, can alternatively be requested from the LOROWERK factory.

- 3** Only for plastic roof sealing sheets. A compression seal is not necessary for bituminous roof sealing sheets.
- 2** Insert a LORO-X sealing element into the socket of the drain body, and coat the whole area with LORO-X lubricant.
- 1** Cut out the thermal insulation on site according to the contours of the drain body. Insert the drain body into the thermal insulation.

2. Mounting the pipe on the roof

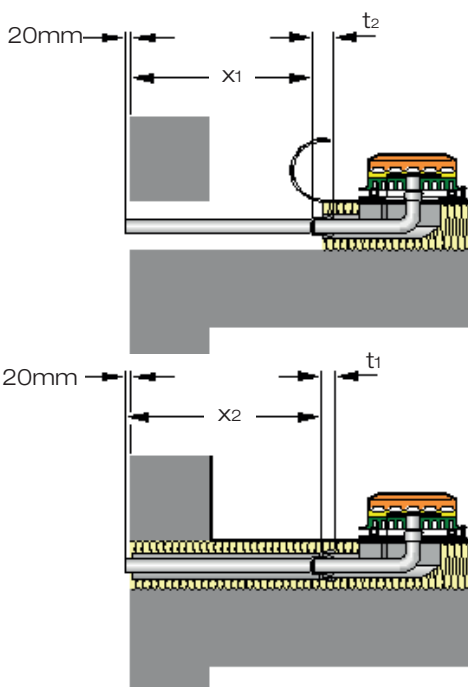

- 2.1** Length of inner pipe DN 50:
Measure the distance between the discharge end of the inner drain pipe (DN 50) and the outer edge of the facade.
Pipe length: $x_1 + t_2 + 20$ mm
The discharge end of the inner pipe must project at least 20 mm beyond the outer edge of the facade. Insert the LORO-X sealing element into the socket of the inner pipe. Push the inner pipe onto the discharge end using LORO lubricant.
Note: roll the roof sealing sheet back, do not bond it yet!

- 2.2** Length of outer pipe DN 100:
Measure the distance between the discharge end of the outer drain pipe (DN 100) and the discharge end of the inner pipe (DN 50).
Pipe length: $x_2 + t_1 - 20$ mm
The discharge end of the outer pipe (DN 100) must be 20 mm shorter than that of the inner pipe (DN 50). Insert the LORO-X sealing element into the socket of the outer pipe. Push the outer pipe onto the discharge end of the outer drain pipe using LORO-X lubricant. Apply a sufficient quantity of thermal insulation to the outer pipe on site and weld the roof sealing sheet in accordance with the instructions provided by the manufacturer of the roof sealing sheet.

3. Installation of the downpipe

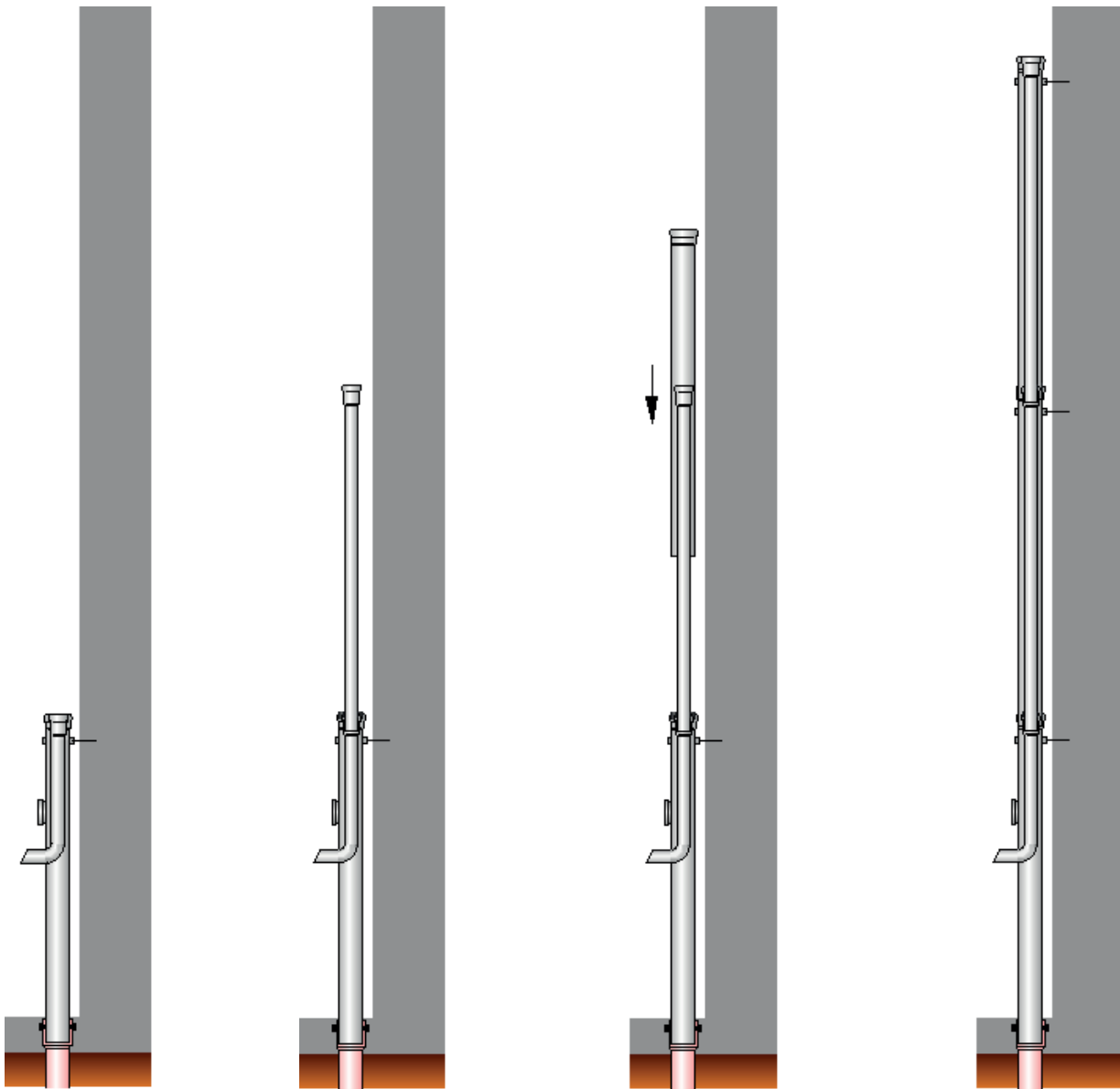

3.1
Installation is to be performed from bottom to top. Connect the LORO-X main-emergency combination rain standpipe to the underground pipe. Fix the downpipe underneath the socket using a LORO-X pipe clip.

3.2
Insert the LORO-X sealing elements into the socket of the inner pipe of the rain standpipe (DN 50) and the socket of the outer pipe of the rain standpipe (DN 100). Coat the sealing elements on the inside and the discharge end of the inner pipe of the downpipe with LORO-X lubricant. Insert the inner pipe of the downpipe into the socket of the inner pipe of the rain standpipe.

3.3
Coat the discharge end of the outer pipe of the downpipe with LORO-X lubricant. Insert the outer pipe of the downpipe over the inner pipe into the socket of the outer pipe of the rain standpipe. Fix the downpipe underneath the socket using a LORO-X pipe clip.

3.4
Repeat steps 3.2 - 3.2 until the parapet opening is reached. Fix the pipes of the downpipe underneath the socket using a LORO-X pipe clip.



3.5

Determine the length of the adaptors for the outer and inner pipe, taking into consideration the LORO-X 'pipe-in-pipe' branch. The closing plug has already been fitted to the socket of the inner pipe DN 50 in the factory. Make the socket joints of adaptors and double pipe branch as described.

3.6

Coat the discharge ends of the pipe on the roof with LORO-X lubricant. Insert the LORO-X sealing elements DN 50 and DN 100 into the sockets of the LORO-X 'pipe-in-pipe' branch and coat with LORO-X lubricant. Release the LORO-X pipe clips. Push the downpipe with the inner pipe socket (DN 50) of the LORO-X 'pipe-in-pipe' branch onto the protruding inner pipe of the roof connecting pipe at a slight angle.

3.7

Fix the downpipe under each socket connection with a LORO-X CN 100 pipe clip. Place the LORO-X ventilation piece onto the downpipe.

LOROWERK K.H.Vahlbrauk GmbH & Co.KG

Kriegerweg 1, 37581 Bad Gandersheim, Germany, Tel. +49(0)53 82.710, Fax: +49(0)53 82.712 03
 Web: www.loro.de, e-mail: infocenter@lorowerk.de

Technical status: March 2011.
 Subject to technical changes.